

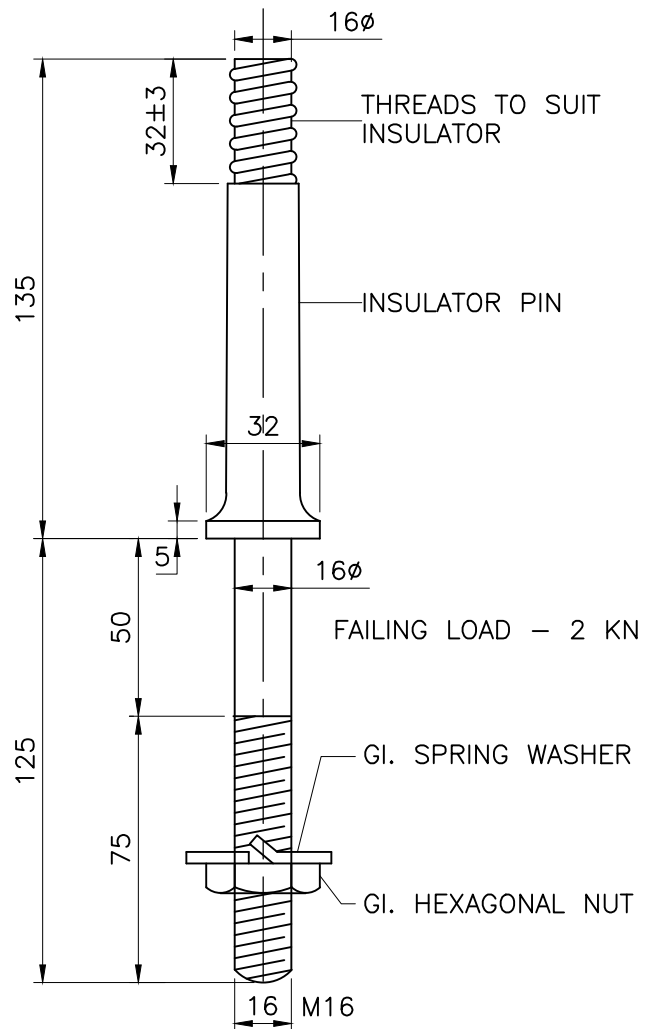

PIN INSULATOR



DETAILS OF FORGED INSULATOR PIN

NOTES:-

1. CONFIRM TO IS-1445(1977)
2. THE UPPER GROOVE OF THE PIN INSULATOR SHOULD BE SLIGHTLY SLANTING SO THAT THE POSSIBILITY OF DAMAGE TO THE CONDUCTOR ON SHARP EDGES IS AVOIDED.
3. IN CASE OF INSULATORS, THE ENCLOSED DIMENSIONS ARE MANDATORY. OTHER DIMENSIONS AND THE PROFILE ARE GIVEN FOR GUIDANCE.
4. TOLERANCES FOR DIMENSIONS WHEN NOT INDICATED IN THE DRAWING SHALL BE AGREED TO BETWEEN THE PURCHASER AND THE SUPPLIER, IF NECESSARY.

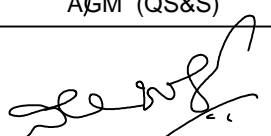
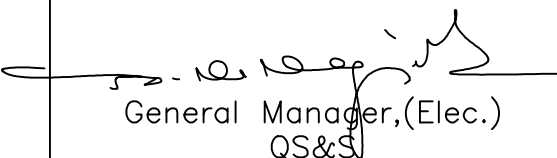
	Signatures	All dimensions are in mm unless otherwise stated.	 BESCOM
Chd	 AGM (QS&S)	1.1 KV CERAMIC PIN INSULATOR WITH GI PIN FOR LT. LINE	Approved:
Sub	 DGM (QS&S)		 General Manager, (Elec.) QS&S
	SCALE: N.T.S		DRG.NO.BESCOM/GM/QS&S/12 REV-002 DATED:24-11-2018