

BOLTS & NUTS (GRADE 5.6) PER STRUCTURE

DESCRIPTION	WT./PCS.	QTY	TOTAL WEIGHT
	Kg	Nos	Kg
M16X75MM LG	0.142	8	1.136
M16X50MM LG	0.180	4	0.72
M16X3.15MM THK PLAIN WASHER	0.011	12	0.018
M16X3.5MM THK SPRING WASHER	0.009	12	0.072
TOTAL WEIGHT			1.95 kg

BILL OF QUANTITY PER STRUCTURE						
ERECTION MARK	SIZE/ DESCRIPTION	LENGTH (MM)	No. of	SECTION WT(Kg)/M	WEIGHT/ PIECE (Kg)	TOTAL WEIGHT (Kg)
1	PLATE 310x12Thk.	310ø	2	94.20	7.11	14.22
2	CHS 168.3x10	3010	1	32.45	118.20	118.2
2A	CHS 168.3x10	588	1	6.34	23.2	23.2
3	RHS 96x48x4.8	1500	2	9.66	14.49	28.98
4	RHS 96x48x4.8	1734	2	9.66	16.75	33.5
5	PLATE 310x12Thk.	310ø	1	94.20	7.11	7.11
6	RHS 96x48x4.8	1100	2	9.66	10.63	21.26
7	RHS 96x48x4.8	850	2	9.66	8.21	16.42
8	RHS 66x33x4.5	1210	2	5.95	7.20	14.40
9	RHS 66x33x4.5	1000	2	5.95	5.95	11.90
10	GUSSET PLATE 97x8Thk.	133	4	62.8	0.81	3.24
10A	GUSSET PLATE 97x8Thk.	133	4	62.8	0.81	3.24
11	PLATE 375x16Thk.	375	1	125.60	17.66	17.66
12	STIFFENER PLATE 100x12Thk.	200	4	94.20	1.88	7.52
13	ISMC 100x50	1500	2	9.56	14.34	28.68
14	12mmx12mm SQUARE ROD	1218	1	1.13	1.38	1.38
15	12mmx12mm SQUARE ROD	1080	1	1.13	1.22	1.22
16	12mmx12mm SQUARE ROD	943	1	1.13	1.07	1.07
17	12mmx12mm SQUARE ROD	806	1	1.13	0.91	0.91
18	12mmx12mm SQUARE ROD	668	1	1.13	0.75	0.75
19	12mmx12mm SQUARE ROD	531	1	1.13	0.60	0.60
20	12mmx12mm SQUARE ROD	394	1	1.13	0.45	0.45
21	12mmx12mm SQUARE ROD	256	1	1.13	0.29	0.29
22	12mmx12mm SQUARE ROD	1458	2	1.13	1.65	3.30
23	12mmx12mm SQUARE ROD	1293	2	1.13	1.46	2.92
24	12mmx12mm SQUARE ROD	1129	2	1.13	1.28	2.56
25	12mmx12mm SQUARE ROD	964	2	1.13	1.09	2.18
26	12mmx12mm SQUARE ROD	799	2	1.13	0.90	1.80
27	12mmx12mm SQUARE ROD	635	2	1.13	0.72	1.44
28	12mmx12mm SQUARE ROD	470	2	1.13	0.53	1.06
29	12mmx12mm SQUARE ROD	1233	1	1.13	1.39	1.39
30	12mmx12mm SQUARE ROD	306	2	1.13	0.35	0.70
31	12mmx12mm SQUARE ROD	1087	1	1.13	1.23	1.23
32	12mmx12mm SQUARE ROD	941	1	1.13	1.06	1.06
33	12mmx12mm SQUARE ROD	795	1	1.13	0.90	0.90
34	12mmx12mm SQUARE ROD	649	1	1.13	0.73	0.73
35	12mmx12mm SQUARE ROD	503	1	1.13	0.57	0.57
36	12mmx12mm SQUARE ROD	357	1	1.13	0.40	0.40
37	12mmx12mm SQUARE ROD	211	1	1.13	0.24	0.24
38	PLATE 250x12Thk.	250	4	94.20	5.89	23.56
TOTAL WEIGHT OF STRUCTURAL STEEL					402.24 Kg.	

SUMMARY OF WEIGHTS:-

WEIGHT OF STRUCTURE	402.24 kg
WEIGHT OF BOLTS & NUTS	1.95 kg
TOTAL WEIGHT	404.19 kg

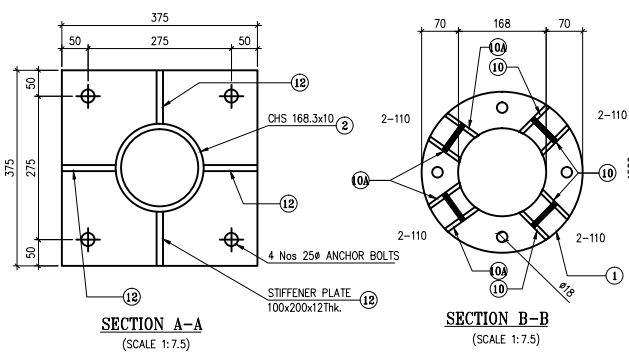

Signatures	All dimensions are in mm unless otherwise stated. GA DRAWING OF TRANSFORMER SUPPORT STRUCTURE	 Approved: _____ General Manager, (Elec.) QS&S
Chd _____ AGM (QS&S)		
Sub _____ DGM (QS&S)	SCALE: N.T.S	DRG.NO.BESCOM/GM/QS&S/70 REV-002 DATED: 24-11-2018